

Projector Images and Room Light Levels

When projectors are used in a variety of classroom and conference room locations it becomes important to determine the projector light level necessary to provide a suitable image. The amount of light provided by the projector is an important factor in determining its image visibility, price and size.

This article describes the concepts related to projector light output and the effects of ambient or background light from other sources in the room. To accomplish this the image contrast ratio is introduced and related to the image light level compared to the background light.

Image on the Screen

To understand the projector and the environment we need to remember that the “image” we see is what counts. The screen is where the “image” appears. The screen acts as the surface that reflects the light in the image back to our eyes. When considering various projection configurations the screen can be much larger than the image. Just remember it is the light from the projector that creates the image, which provides the information or picture of interest.

For a projector, the number of “lumens” indicates the amount of light coming from the lens. For an all white image, the light is distributed evenly over the image when it is projected on the screen. An actual image can be composed of dark areas where the light is not present or other area where there is a color such as red or green. However, a projector is rated for the maximum amount of light with a full white image.

One way to think about the light from the projector is that it is analogous to water coming out of a showerhead. As the distance from the showerhead increases the spray spreads out over a larger area. The amount of water remains constant whether one is close to the showerhead or further back. What happens as we get further away is that the amount of water over a fixed small area like your hand becomes less.

This same effect happens with the projector light as we increase the image size. The light over a small fixed area becomes less. There is still the same total amount of light, but it just gets spread over the larger image.

As mentioned, light is measured by a unit called “lumen”. A projector provides a certain number of lumens. The lumens are distributed over the image area. To determine the actual lumen level, a full white image is projected and measurements taken at nine locations in the white image. The image size is also measured and the total lumens calculated.

As the image is becomes larger, there are less lumens present in any fixed area such as a square foot (an area equal to 1 foot by 1 foot). The lower the light in a unit area, the less bright the image becomes.

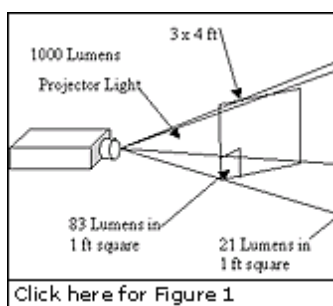

For example, an image of 3x4 feet has an area of 12 square feet. If the projector has a 1000 lumen output then there are $1000/12= 83$ lumens in each square foot of the image as shown in Figure 1.

If the image on the screen is increased to 6x8 feet by projecting at a longer distance, then the area is 48 square feet and the lumens per square foot becomes $1000/48= 21$ lumens per sq. ft. Thus by increasing the image size 4 times, we have reduced the lumens per sq. ft. by 4 times. Again see Figure 1.

Since lumens describe the amount of light used to produce the image, it is directly related to what our eyes see, and is what we call the image brightness. For this example when the image size was increased 4 times the brightness was reduced by 4 times.

It is important to remember that the image brightness is determined by the size of the image projected. For projectors we can move them closer to the screen to produce smaller images that are brighter. However, we usually employ the projector to provide a large image. Thus there is a tradeoff between the image size and the brightness for any projector. To increase the image size and keep the same brightness image, we must use a projector that outputs more lumens.

Employing a higher output projector appears to be a simple solution, but the lumen output is one of the primary factors that govern the cost of the projector. Consequently, in the real world, a good choice is a projector with the

minimum number of lumens to get the job done.

A second important consideration is that in most rooms there is another source of light that falls on the screen. This is the ambient or background light from windows and lamps in the room.

Background Light

Most projector environments are never totally dark. The ambient light that falls on the screen produces a background light level with the image being projected on top. It is this background or ambient light that must be considered when determining how large an image should be and how many lumens are needed.

To understand this we can extend the shower analogy. If the shower is located outdoors when a rainstorm is in progress there is additional water along with water from the showerhead.

Thinking about this situation we all know that as the background light increases, it becomes more difficult to see a projected image. The image becomes dull and it may appear "washed out".

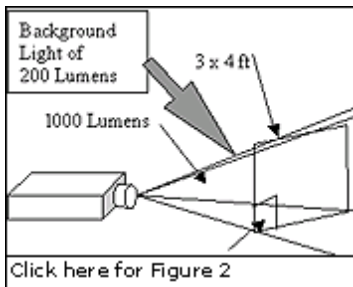

What really is happening is that the image had its "contrast" reduced by the ambient light. The amount of light contributing to the image remains the same, however, more light has been added to the screen by other light sources in the room.

Consider the situation as shown in Figure 2, where the room lights contribute 200 ambient lumens over the total 3x4 foot screen. For an image, this results in a background light level of $200/12 = 16$ lumens for each square foot of the screen. Now if our projector provided 83 lumens on each square foot when the image was white, then total amount of light on the area is $83+16 = 99$ lumens.

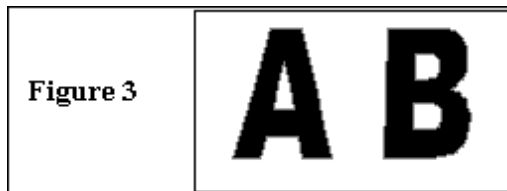

This may initially appear to be a benefit since the light level has increased, however, where the image has no light, in a dark area, there is still the 16 lumens present. Since images are composed of bright and dark regions as shown in Figure 3, we can consider the effect on the image by considering the "contrast".

Image Contrast

The "contrast" is a measure of the brightest to the darkest area of the image. The contrast of the prior example is just the 99 lumen bright level divided by the dark level of 16 or $99/16 = 6$. If we double the light from the projector to 2000 lumens the contrast almost doubles. The bright region is 182 ($83+83+16$) divided by the dark level still at 16, or $182/16 = 11$. Thus the contrast has gone from 6 to 11.

If on the other hand, when the amount of room light is doubled, the bright area level becomes 115, ($83+32$) and the dark region increases to 32 lumens. Thus the contrast is $115/32 = 4$. With a contrast as low as 4, we must ask what is a good contrast for the image on the screen?

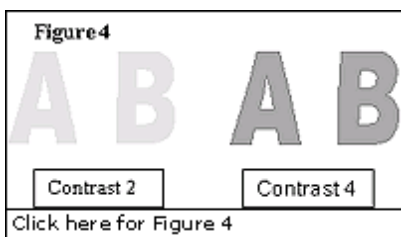

As shown in Figure 4, contrast levels of 2 let us see the image but not very clearly. A contrast of 20 permits viewing most images but does still not product a rich vibrant image. Contrast levels in excess of 200 produce great images.

Most projectors today produce images with contrasts exceeding 200, however when projected on a screen with room light present the resulting contrast is far less. How can we know what effect the room light will have on the resulting contrast and can we determine the amount of light needed from the projector?

Another way to consider the situation is to ask how much do we need to reduce the ambient light level to produce a suitable image?

There are several ways to answer these questions. One is by a trial with various light level projectors. Another way is measuring the amount of room light on the screen and estimating the contrast.

Still another way is to use a projector with a known lumen output and set the image size to simulate a larger image with increased lumen output. To do this, one way is to take the known lumen projector and make the image 1/4 of the size of the image desired. If this image has a satisfactory brightness and contrast then you need a projector that has 4 times the amount of lumens.

For example, if we go back to the example where we had a 1000 lumen projector the image can be projected to a 3x4 ft. area on a larger screen. If the image contrast is satisfactory, then this lumen level could be predicted for a larger image size. An image of 6x8 ft. will have an area 4 times larger and thus the projector will be required to deliver 4000 lumens to form an equivalent contrast image. The factors for the various image sizes are shown in Table 1.

Table 1			
Image size in feet (H x W)	Image Diagonal in inches (4 to 3 aspect)	Area Factor	Area of image in sq. feet
3x4	60 inches	1	12
6x8	120 inches	4	48
9x12	180 inches	9	108

Ambient Light Levels

Another option is to reduce the background light. This could consist of blocking the light from windows and turning down the lights to reduce the light falling on the screen.

Table 2 presents some typical light levels for various environments. In most cases the very dark theater setting does not work well for school, conference, or lecture rooms. For most cases the average background at the screen is usually under 2 lumens per square foot.

Table 2	
Condition	Background level in lumens per square foot
Movie theater	0.1
Low light level room	1 to 2
Normal room	30 to 60
Desktop for reading	40 to 60
Room with window, no sun	50 to 100
Room with window, sun	1,000 to 5,000
Outdoors	5,000 to 10,000

In some cases where windows are present it becomes very difficult to block the light. However, in any case where sunlight is entering the room some form of shading is typically required. This is because direct sunlight has a tremendous amount of lumens. One 3x3 foot window can easily permit over 2000 lumens to enter the room.

Compare this to the case where the background is only 2 lumens per square foot and the projector has an output of 1000 lumens. Here the maximum contrast for a 4x3 foot image is the 83 lumens from the screen plus the 2 lumens background to yield 85 lumens in a bright area and 2 lumens in the dark for a contrast of 42 (85/2). A contrast of 42 may not seem high but it is what people typically observe in rooms with a comfortable lower light level.

Summary

Using the concepts described we can evaluate different projectors and the effect from the environment. Remember the light from the projector is not reduced as it crosses the space to the screen. However, if the projected image becomes larger, the light in a fixed area becomes less and the image appears less bright. We now know how to calculate the change using the image area.

The second major factor is the background light. This causes the image to become washed out or reduces the contrast.

Many projectors today are in the 1000 to 3000 lumen range and the background light level will be a major factor in determining the contrast. Consequently it is important that for an optimum image the background light be reduced down to the lowest level possible.

There are other ways to predict the contrast such as using a light meter to measure the amount of lumens. In addition there are special screens and rear projection configurations that improve the contrast. While these methods do provide higher contrast levels they typically require an increased cost.

With existing projectors and a simple screen we are usually limited to the option of controlling the background light. However, even when employing higher light output projectors there still may be a problem with the background light. That is because of the tremendous amount of light during normal daylight or the indoor light levels we prefer for comfortable living. Thus, in almost all projector installations the image brightness and contrast become the most important factors.

AV Products Division
2900 Dukane Drive
St. Charles, IL 60174
630.762.4041

InfoComm International® www.infocomm.org Questions? Contact website@infocomm.org